

TANA
From Waste to Value®

Landfill Compactor

ECO E450

**THE MOST PRODUCTIVE
COMPACTOR ON THE MARKET**

Unique design

Twin drums Fewer passes, smooth and dense surface

Rigid frame Best crushing force

Crushing teeth Optimized size, shape and number for optimized spreading and crushing of waste

TANA ProTrack® To minimize downtime and improve cost analysis



CRUSHING FORCE

TANA E450eco Landfill Compactor

GENERAL INFORMATION

Weight	45 000 kg
Total length	9 230 mm
Total width	4 950 mm
Total height	4 320 mm
Wheel base	4 050 mm
Ground clearance	890 mm
Length without dozer blade	7 430 mm
Width without dozer blade	4 390 mm
Inside turning radius	3 310 mm
Driving speed ranges	0–5 km/h 0–7 km/h
Maximum crushing force	221 kN

COMPACTION DRUMS

Uniform full width drums with forged solid steel crushing teeth. Adjustable scraper bars on both sides of the drums and adjustable steel wire cutters in the ends of drums.

	Front/rear drum
Crushing/compaction width	3 800 mm/3 800 mm
Diameter including crushing teeth	1 620 mm/1 620 mm
Number of crushing teeth	110 pcs/110 pcs
Height of crushing teeth	200 mm/200 mm
Number of scraper bars	20 pcs/20 pcs
Number of wire cutters	2 pcs/4 pcs

DOZER BLADE

The dozer blade is operated with two hydraulic cylinders and it is equipped with two arms. Arm joints are with hardened pins and spherical bearings.

- Width
- Height
- Movement above ground level
- Movement below ground level
- Upper part of blade: trash screen
- Bolt-mounted reversible cutting edges

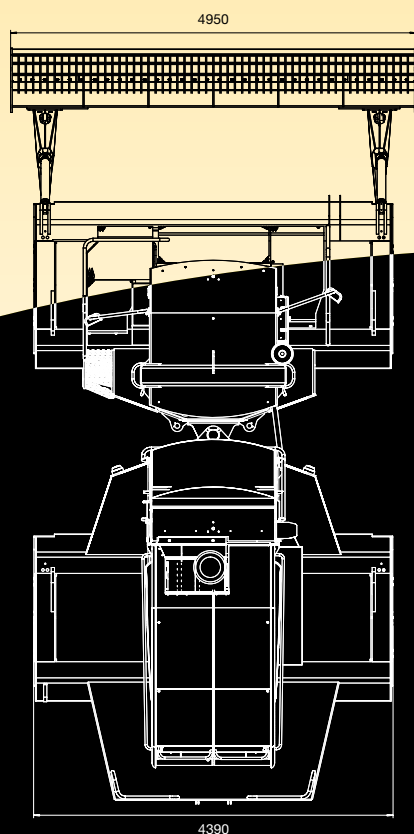

FRAME

The frame is constructed of two modular drum frames connected together with a longitudinal upper frame. The drum frame acts as a shell around the drum, which helps to prevent waste raising to the upper parts of the machine from below.

The upper frame is equipped with center point articulated steering operated with two hydraulic cylinders.

- Articulation links are equipped with hardened pins and spherical steel bearings
- The angle of articulation to the left or right is 40 degrees

SERVICE PLATFORMS AND PROTECTION

Service platforms and steps are equipped with banisters and anti-slide surfaces. Engine and powerpack are protected with lockable hood (bonnet). Opening of hood is made easier by using wind hooks.

VANDALISM PROTECTION

- Lockable cabin, engine compartment and fuel tank filling cap
- Electronic key for ignition

ENGINE

Cummins QSX15-C535

- Turbo charged, 6 cylinders in line, water-cooled, after-cooled, four-stroke diesel engine
- Fulfills U.S. EPA Tier 4 (f), CARB Tier 4 and EU Stage IV non-road emission certificates
- Maximum power: 580 BHP (433kW)/1 800 RPM
- Power rating: 535 BHP (399kW)/2 100 RPM
- Maximum torque: 2 644 Nm (1 950 lb-ft)/1 400 RPM

Engine equipment

- Attachment to the frame with vibration and noise damping rubber mounts
- Service indicator
- Dry-type air cleaner with replaceable primary and safety element
- Fuel filter and water separator
- Oil filter
- Radiator + separate charge air cooler
- Aftertreatment system

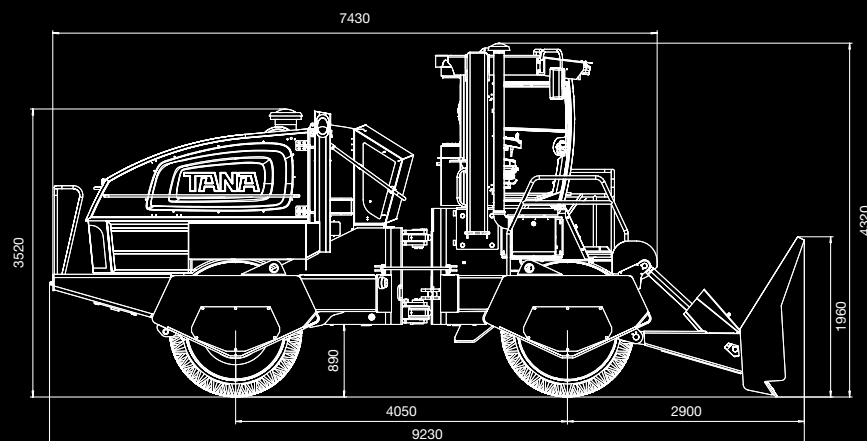

CABIN AND CONTROLS

Equipment

- Pressurized, heat and sound insulated cabin with cabin lights
- Insulation materials in accordance with ISO 3795
- Air-suspended swivelling operator's seat with head rest, built-on controls, seat heating and seat belt
- Laminated safety glass windows
- Socket for mobile phone charger, radio/CD/USB player
- Front and rear windshield intermittent wipers and washers, suncover in front
- Heater and A/C unit
- Emergency exit, lockable door, shelf and lockers, external rear window mirrors, foot support, inside mirror
- Replaceable cabin air filters
 - pre-filter grade EU3
 - micro filter grade EU7, grade EU14 (option)
 - active carbon filter (option)

Gauges included in TANA Control System (TCS)

- Engine oil pressure, temperatures for engine intake manifold, engine oil and hydraulic oil, coolant and hydraulic oil
- Final drive gearbox temperatures
- Fuel level, total fuel consumption
- Voltage, tachometer, boost pressure, engine working hours
- Engine load rate

System warnings in TCS

(indicator light, acoustic warning and alarm log)

- Engine air filter contamination
- Hydraulic oil temperature
- Low hydraulic oil level
- High hydraulic oil contamination
- Fuel level
- Gear box temperature
- Hydraulic oil return line filter clogging
- Charge pressure filter contamination
- Low charge pressure
- Voltage
- In addition to above all the alarms from the diesel engine control module (95 different alarms, including low engine oil pressure, high coolant temperature, etc). Totally more than 500 alarms.

Controls

- Transmission on/off and parking brake
- Emergency shut down
- Ignition switch: power on/off and starting
- Heater and air conditioning, cabin temperature control
- Windshield wipers and washers, lights

Joystick controls integrated in arm-rests

- Return to neutral position automatically when released and all related movements will cease
- Left hand joystick for control of driving speed and direction as well as control of optional bucket and speed range selection by pressing a button
- Right hand joystick for control of steering, dozer blade and horn

ROPS / FOPS

Integrated in cabin structure

- ROPS in accordance with ISO 3471:2008
- FOPS in accordance with ISO 3449:2005

TANA ProTrack®

- Offers on-line information
- Monthly operational reports
- GPS available



State of the art information management system

Maximum uptime

- Remote access for quicker and more accurate trouble shooting by the distributor and TANA technical support
- Critical alarm notifications to several receivers by e-mail
- Reminders for scheduled maintenance to several receivers by e-mail

Accuracy to cost follow-up through TANA ProTrack® reports (additional option)

- Monthly operational reports to given e-mails on e.g. working hours, fuel consumption, work load...

POWER TRANSMISSION

- Closed circuit, hydrostatic transmission
- Separate systems for both drums
- Two driving speed ranges
- Control of driving speed and direction with one lever
- Stepless speed control

Pumps

- One tandem pump arrangement
- Variable displacement axial piston pumps with electrical proportional control

Motors

- Four variable displacement plug-in motors

Cooling of hydraulic system

- Air-operated oil cooler
- Openable air filtration screen

Hydraulic oil filtration

- Return line filter and two charge pressure filters, hydraulic oil filling filter

Final drive gear boxes

- Transmits hydraulic output to the drums
- Three-stage planetary gearboxes (2 pcs)
- Integrated hydraulic oil pressure released multi-plate parking brake
- Splash lubrication system

BRAKES

- Service brakes: hydrostatic transmission acts as service brakes, separate circuits for both drums
- Parking/emergency brakes: hydraulic oil-released, spring-actuated multi-plate parking brake integrated in planetary gear boxes

AUXILIARY HYDRAULICS

Open circuit system with electro-hydraulic load sensing (LS) control.

Pump

- Variable displacement axial piston pump

Directional control valve

- Electro-hydraulic proportional control

HYDRAULIC OIL TANK

The hydraulic oil tank is located inside the engine hood

- Electrical filling pump with filter
- Oil level sensor with alarm
- Breather filter

FUEL TANK

The 655 l tank is located inside the upper frame under the operator cabin

- Lockable filling cap
- Service hatch
- Suction strainer
- Drain valve
- Level sensor with alarm

UREA TANK

The 56 l tank is located inside the rear frame. It is equipped with a suction strainer and level sensor with alarm.

ELECTRICAL EQUIPMENT

- 24 VDC system
- Batteries 12 V 180 Ah, 2 pcs
- Lights: front 4 pcs, rear 4 pcs
- Horn
- Socket for hand light in engine compartment
- Back-up alarm, main circuit breaker, voltage reducer for radio

For details, please contact your local distributor or visit the manufacturer's web page at www.tana.fi

Weights and measurements are given within normal tolerances. Manufacturer reserves the right to alter the above as necessary. Some features shown may be optional and not standard.



TANA compaction drums – two full width drums with forged solid steel crushing teeth.

TANA

From Waste to Value®

Tana Oy

P.O. Box 160, Schaumanin puistotie 1
FI-40101 Jyväskylä, FINLAND
Tel. +358 20 7290 240
E-mail: mail@tana.fi

Your local Tana distributor: