

**TANA**

# TANA MULTI WASTE BUCKETS

**TANA MWB | PRE-SHREDDING BUCKETS**

**TANA FROM WASTE TO VALUE®**

# Changing the narrative of pre-shredding



Pre-shredding is the first step in efficient waste processing, where bulky, mixed, or unsorted materials are reduced into smaller, manageable pieces to improve downstream sorting, screening, recycling, and energy recovery.

The TANA Multi Waste Bucket (MWB) brings pre-shredding directly to the loading stage, enabling crushing, mixing, and bag opening without a separate shredder.

With the TANA MWB, you can reduce transport volumes, lower operating costs, improve material recovery, and achieve a safer, more efficient waste processing operation.



TANA  
MWB17

TANA

### Better flow, better results

- ▶ **Operational flexibility** – Pre-shredding can be done directly at the loading stage, adapting easily to different waste types.
- ▶ **Improved material recovery** – Better preparation of waste streams enables more accurate sorting and higher-value output fractions.
- ▶ **Improved safety** – Less manual handling and safer working conditions in waste yards and processing facilities.

### Lower costs, smarter investments

- ▶ **Lower investment costs** – Pre-shredding with TANA MWB buckets reduces or eliminates the need for a separate pre-shredder.
- ▶ **Reduced transport and storage costs** – Smaller, denser material means fewer loads and better use of available space.
- ▶ **Lower operating and maintenance costs** – Reduced wear on downstream equipment and fewer processing bottlenecks.

# Special features of TANA MWB

- **Adapter plates** are available to enable use with any wheel loader or material handler.

• **Main process direction** enables material bed to turn constantly inside the bucket, maximizing the capacity.

## Three-axle design to enable efficient shredding

• **The upper and lower axles deliver 27% higher torque** than the middle axle, enabling efficient cutting against fixed counter blades.

• **The middle axle runs 27% faster** than the upper and lower axles, increasing capacity and creating a coincidental cutting pattern that prevents material wrapping.

• **Open structure** allows fast, safe cleaning and reduced downtime.

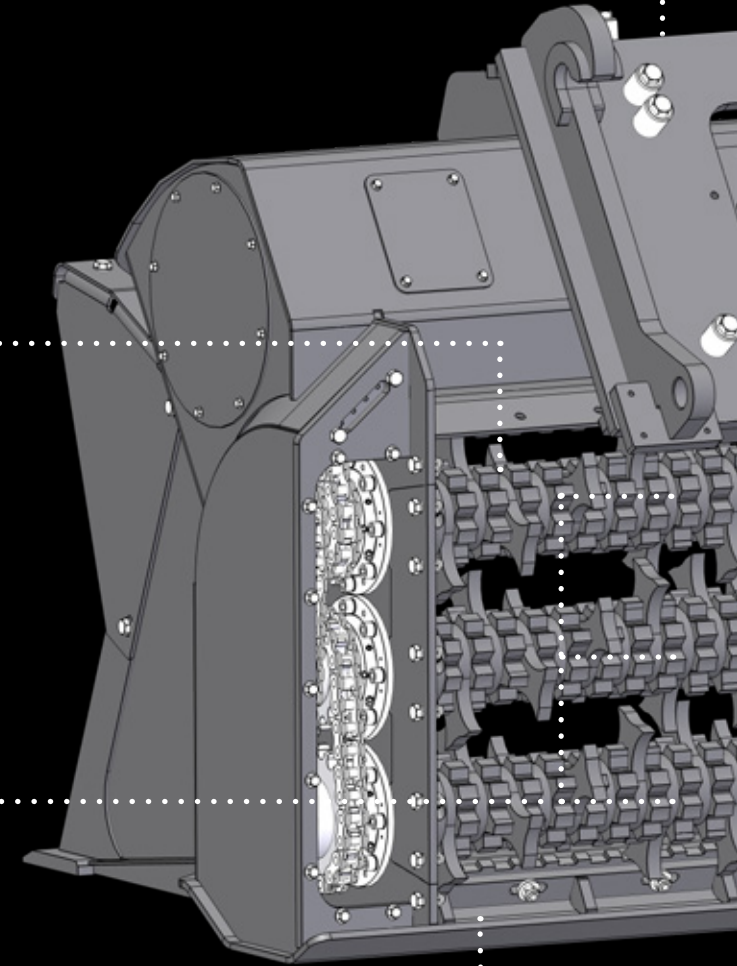

**Drain line not needed** – plug and play with any wheel loader.

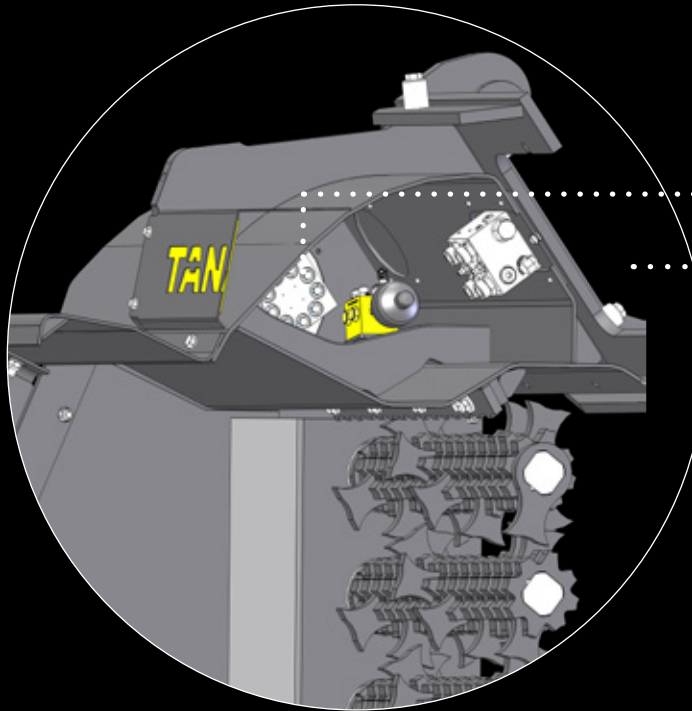
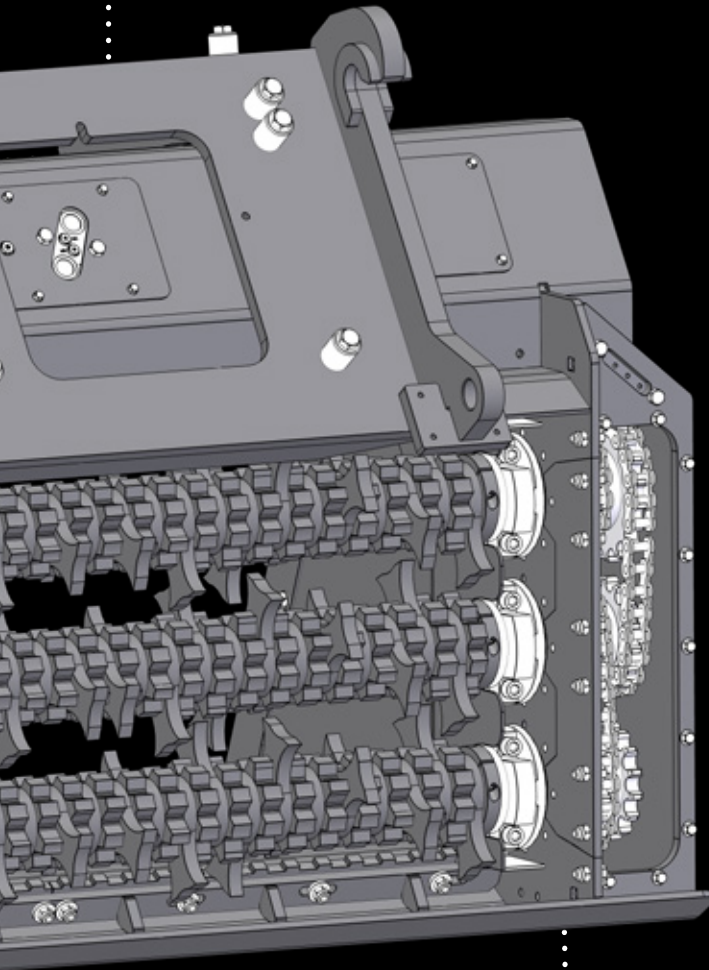

**Dual motors with heavy-duty double chain transmission** maximize component lifetime and reliability.

**Bi-directional axles** enable continuous operation and high throughput.

**Each axe blade works against a knuckled sleeve on the opposite axle**, acting as a rotating counter blade. The low and high knuckles reduce wrapping and promote self-cleaning.

**Axe-shaped blades** enable safe manual sharpening without removing the rotors, minimizing maintenance time.

**Patented bearing protection fender** protects bearings from wrapping and contamination, extending service intervals.

**Quick-change axle design with freely sliding blades and sleeves** makes wear parts fast and easy to replace.

# Technical features



25mm axe blades with toothed ring sleeves

Middle drum rotates faster than top and bottom for better self-cleaning

Blades can be sharpened with an angle grinder

Shafts and blades can be easily replaced

No additional drain line is needed  
– compatible with most waste yard machines (wheel loaders, telehandlers)

	<b>TANA MWB17</b>	<b>TANA MWB23</b>
Wheel loader range	10-15 tn	13-20 tn
Loading volume	1,2-1,6 m <sup>3</sup>	1,6-2,1 m <sup>3</sup>
Weight	2000 kg	2400 kg
Oil flow range	150-230 l/min	190-300 l/min
Max. inlet pressure	300 bar	300 bar
Drum revs	120-180 rpm	120-180 rpm
Motors	2 x MAV630	2 x MAV800

**Produced particle size: 300-400 mm (2D)**

**Processing capacity: up to 90 m<sup>3</sup>/h**

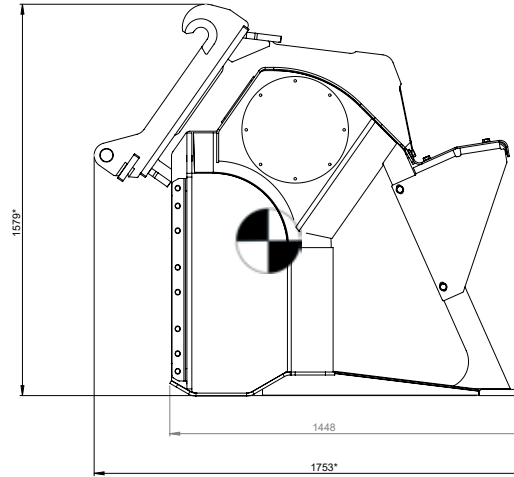
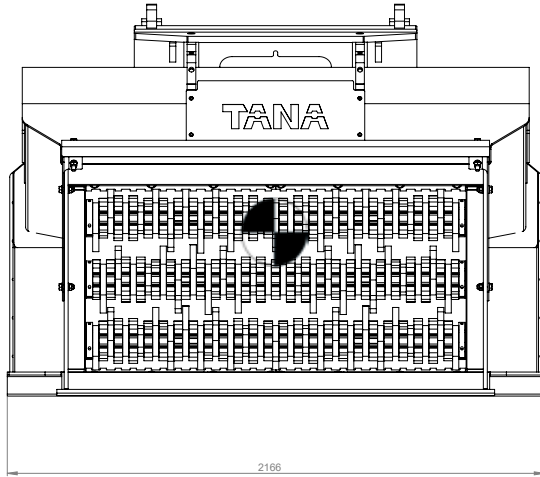

**TANA MWB17**

NOTE: Dimensions marked with '\*' may vary between different adapter types

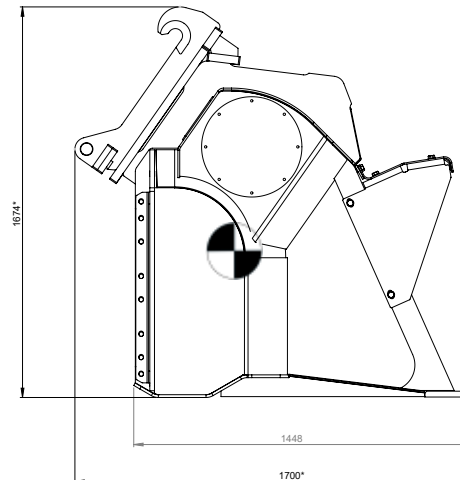
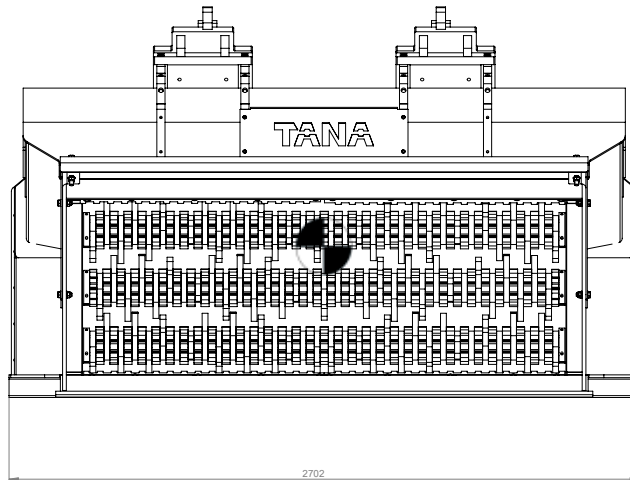

**TANA MWB23**

**TANA**

# CONTACT US

## **Tana Oy**

P.O. Box 160  
Schaumanin puistotie 1  
FI-40101 Jyväskylä  
Finland  
Tel. +358 20 7290 240  
E-mail: [mail@tana.fi](mailto:mail@tana.fi)  
[www.tana.fi](http://www.tana.fi)

Your local Tana distributor:

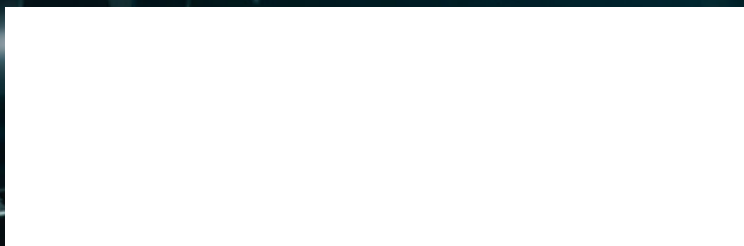

**TANA FROM WASTE TO VALUE®**

Ver. 03/2026